



IN-LINE BASKET FILTERS "FBX"

CDB engineering fabricated basket strainers have been specifically designed to meet all customer requirements including for high pressure applications. Designed and fabricated to ASME VIII Div.1 as standard but can also be supplied to other pressure vessel codes. I.e. ASME B31.3 etc. Standard features include low pressure drops at high velocities, stainless steel perforated baskets as standard, vents and drains with the possibility to supply davit lifts, quick open closures, DP gauges. We are also able to manufacture against customer requests in all types of sizes & materials. Simplex filters are a simple and efficient system to protect vital plant equipment such as pumps, compressors, heat exchangers, flowmeter, etc.

Quick opening cover *



POS.	DESCR.	MAT.	spare
1	Body	C.S.	
2	Cover	A105N	
3	Gasket	SW	X
4	Studs	A193B7	
5	Nuts	A194 2H	
6	Screen	SS304	x
6	Perf. Plate	SS304	
6	Mesh	SS304	
7	Drain	A105N	
8	Vent	A105N	
9	Lifting eyes	C.S.	
10	Legs	C.S.	
11	Davit*	C.S.	
* optional			

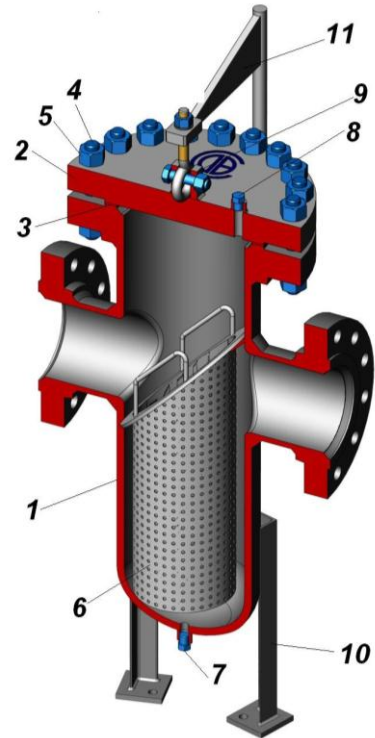

CONNECTIONS	
Buttweld	Asme B16.25
Flanged	Asme b16.5

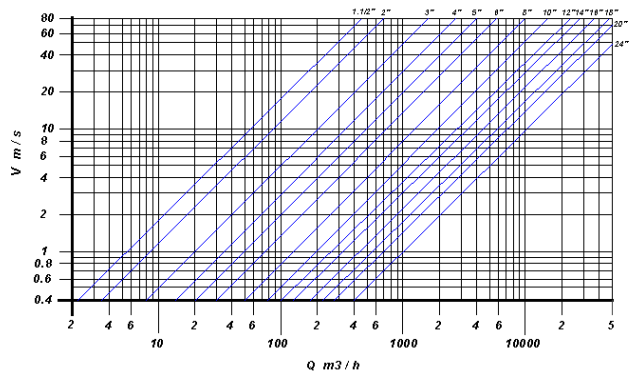
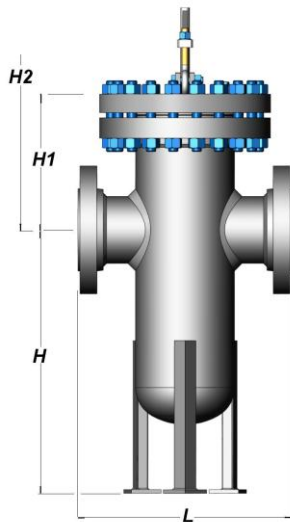

Size	1½"	2"	3"	4"	5"	6"	8"	10"	12"	14"	16"	18"	20"	24"
L 150 #	330	350	350	540	560	600	650	740	860	1000	1000	1200	1400	1500
L 300#	356	370	560	406	445	553	584	838	914	965	1092	1092	1130	1264
H (mm)	305	305	318	356	381	432	533	635	711	838	914	991	1118	1524
H1 (mm)	163	178	203	210	241	241	279	330	368	400	464	464	553	553
H2 (mm)	300	350	400	450	500	510	600	700	800	850	900	1000	1100	1200
Kg	40.0	43.1	46.7	77.1	105	109	154	272	349	440	617	635	870	997

CDB Engineering reserve the right to carry out any necessary modification without prior notice